

CONSTRUCTION (m/m)

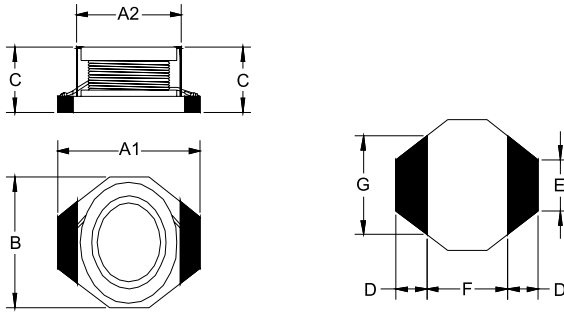

A1: 6.6 MAX. A2: 4.06 B: 4.45 MAX. C: 2.92 MAX.
D: 1.02 E: 1.27 F: 4.32 G: 3.05

ELECTRICAL SPECIFICATION

ITEM	L	DCR	SRF	IDC
HPBP064403	(μ H)	MAX.(Ω)	Min.(MHz)	MAX.(A)
1R0M	1.0 \pm 20%	0.040	250	3.0
1R5M	1.5 \pm 20%	0.045	125	2.8
2R2M	2.2 \pm 20%	0.050	120	1.8
3R3M	3.3 \pm 20%	0.055	120	1.6
4R7M	4.7 \pm 20%	0.060	105	1.4
6R8M	6.8 \pm 20%	0.065	50	1.2
100M	10 \pm 20%	0.075	38	1.0
150M	15 \pm 20%	0.090	33	0.80
220M	22 \pm 20%	0.11	25	0.70
330M	33 \pm 20%	0.19	20	0.60
470M	47 \pm 20%	0.23	20	0.50
680M	68 \pm 20%	0.29	15	0.40
101M	100 \pm 20%	0.48	10	0.30
151M	150 \pm 20%	0.59	9	0.26
221M	220 \pm 20%	0.77	6	0.22
331M	330 \pm 20%	1.4	5	0.20
471M	470 \pm 20%	1.8	4	0.19
681M	680 \pm 20%	2.2	3	0.18
102M	1000 \pm 20%	3.4	2	0.15
152M	1500 \pm 20%	4.2	2	0.12
222M	2200 \pm 20%	8.5	2	0.10
332M	3300 \pm 20%	11.0	1	0.08
472M	4700 \pm 20%	13.9	1	0.06
682M	6800 \pm 20%	25.0	1	0.04
103M	10000 \pm 20%	35.0	0.8	0.02

HPBP064403 TYPE



SPECIALIZE IN HIGH CURRENT & HIGH
INDUCTANCE FOR SMD INDUCTORS

COIL CODE

HPBP 064403 100 M

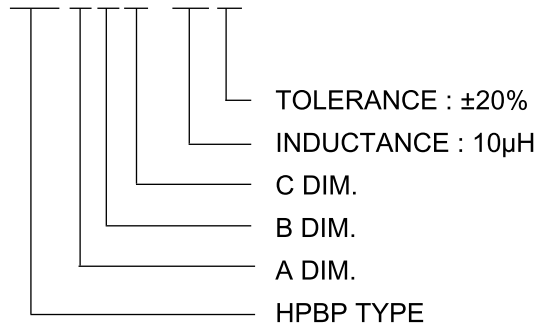

CHARACTERISTICS

- TESTED AT 100 KHz, 0.1 VRMS
- OPERATING TEMPERATURE RANGE :
-40 $^{\circ}$ C TO +85 $^{\circ}$ C
- ELECTRICAL SPECIFICATIONS AT 25 $^{\circ}$ C
- IDC2; BASE ON TEMP. (AT=30 $^{\circ}$ C)

* Hong can design any part to your requirements with different inductance.

* All parameters as this content presented are subject to final specifications both sides confirmed.